

COEN
COMPOSITE WOOD

HABITAT SCREENING

PRODUCT GUIDE
INSTALLATION
TECHNICAL SPECIFICATIONS
CARE & MAINTENANCE

SCREENING

COEN
COMPOSITE WOOD

COEN Composite Wood is a new type of composite (WPC) made by mixing 60% wood powder with 28% HDPE and 12% additives. These are extruded through our modern CNC high pressure / temperature extrusion machines.

Our WPC not only has a high degree of anti-UV and weather resistance, but is also easy to work with and

install. COEN WPC's are highly resistant to moisture, so there is no "Wood Rot" and termites just don't seem to like getting near our products. No cracking, warping or splintering ensures an efficient and easy installation process for our builders. We also have a very stable UV product, so the colour will have very minimal fading from the harsh Australian conditions.

BENEFITS OF COEN



PRODUCT DESIGN &
INSTALLATION OPTIONS



HIGH DURABILITY



DOESN'T ABSORB WATER,



MINIMAL COLOUR FADE



HIGH MECHANICAL



EXCELLENT DIMENSIONAL STABILITY



EASY CLEANING,

Easy to install screening made to last in Australian conditions, with no oiling or sealing required.



PROFILE DRAWINGS

SOLID PROFILES

(Shown at 1:2)

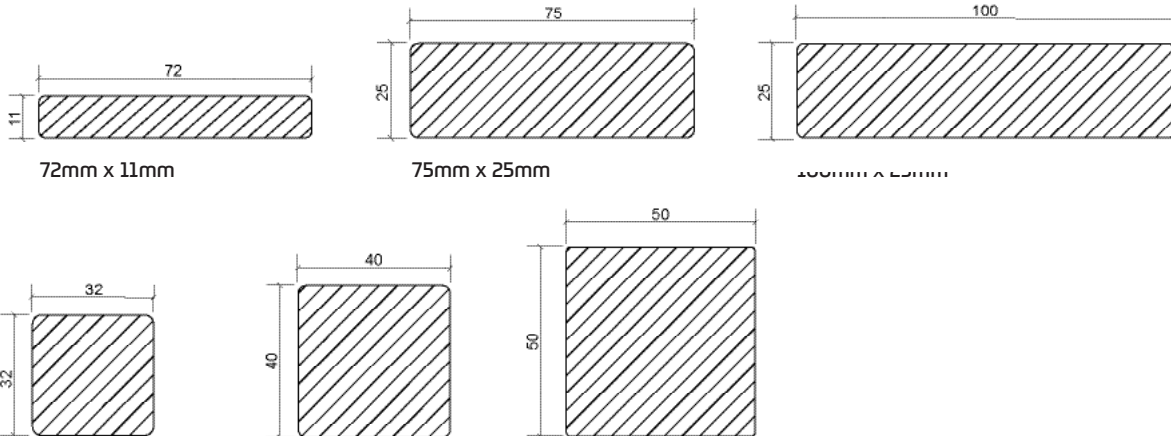

HOLLOW PROFILES

(Shown at 1:2)

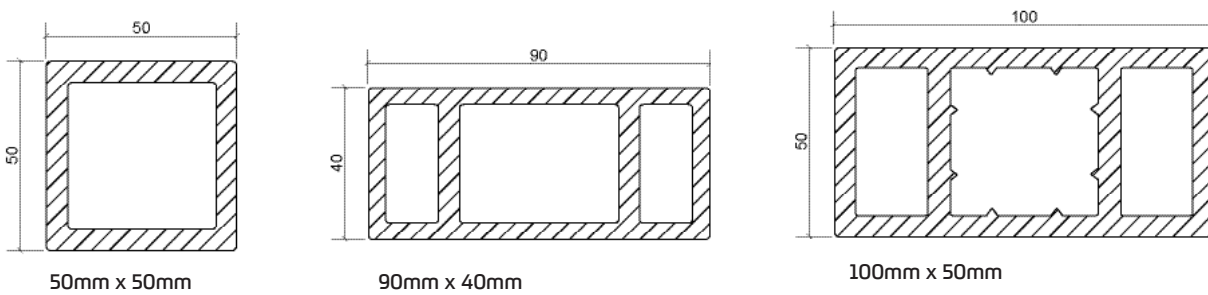

STANDARD FINISH



CHARCOAL

OAK

ASH GREY

JARRAH

SANDED

Colours and finishes shown here are approximate representations only. Additional colours and finishes are available on request.

INSTALLATION TOOLS AND ACCESSORIES



CIRCULAR SAW

Cut COEN composite wood to specific lengths on site to meet installation requirements.



HAND DRILL

Since Composite materials have a higher density, all screw holes should be pre-drilled.



ELECTRIC HAMMER DRILL

Use a Hammer Drill for securing battens to solid wall surfaces.



TAPE MEASURE



LEVEL



STAINLESS STEEL SCREWS



SCREENING BATTENS



CN-40x30-Joist*

SAFETY

When cutting, drilling or hand sawing any WPC material, ensure you wear a dust mask, safety glasses and ear protection.

*Joists should be made of suitable material for the purpose – for example, treated pine timber, steel, aluminium or specific composite battens (CN-40x30-joist).

BATTEN INSTALLATION (IF APPLICABLE)

NB. The supporting wall must be watertight and correct flashings used in the event of any water penetration i.e. severe storms. Avoid designs that allow moisture build-up.

There must be ventilation/drainage at the base of the wall. Terminate joists at least 10 mm from the floor/ground.



Screening must be secured with a minimum number of fixing points, ie:

2m = 2 fixing points

3m = 3 fixing points

4m = 4 fixing points

First fixing point to be no more than 100mm to 200mm from the end of the screen.

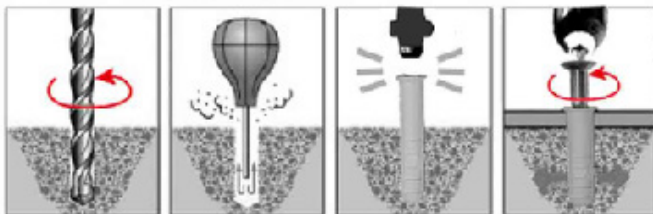
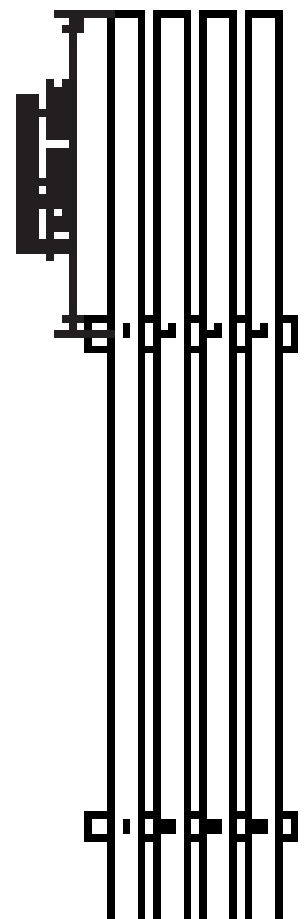

Fix battens to the wall with expansion screws, at 500mm centres.



Expansion Screw

HOLLOW SCREENING

We recommend using Delta-seal Washer Head or similar Stainless Steel Screws in sizes appropriate for the screen depth.

Select a screw 20-30mm longer than the depth of your screen to ensure secure fixing to batten.

Do not countersink.

1. Drill pilot hole through screen and batten at shank diameter.
2. Then drill clearance hole 2mm wider than the screw thread diameter (this will allow for thermal expansion of the composite material). The hole should go through the front face and any internal webbing.
3. Secure screws through screen and onto batten with low to medium torque.

Note. Do not overtighten on any hollow screening product.

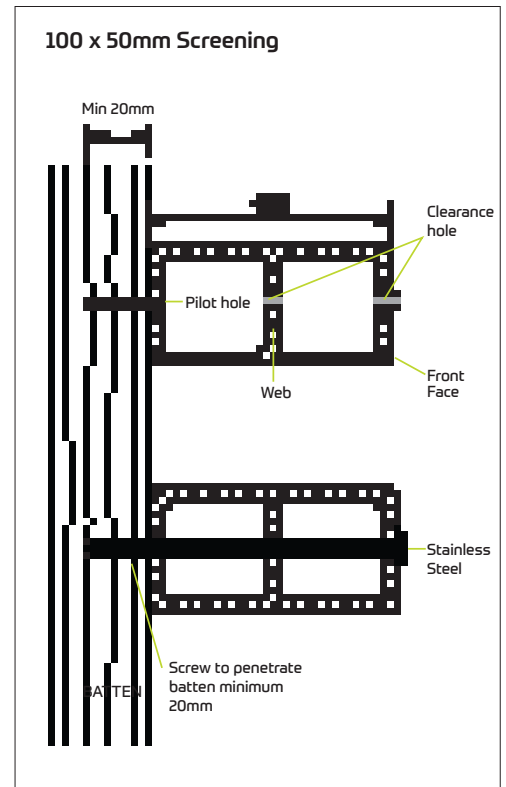
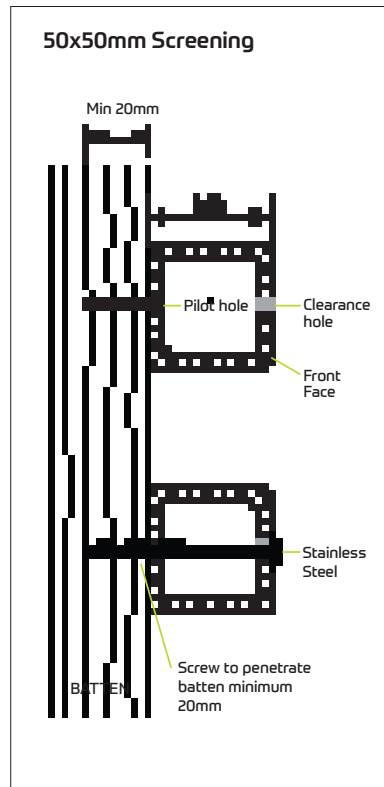

SOLID SCREENING

We recommend using TX Countersunk Facade or similar Stainless Steel Screws in sizes appropriate for the screen depth.

Select a screw 20-30mm longer than the depth of your screen to ensure secure fixing to batten.

1. Drill pilot hole through screen and batten at shank diameter.
2. Drill clearance hole in screen 2mm wider than the screw thread diameter and countersink hole to match screw head.
3. Countersink screws through screen and onto batten with low to medium torque.
4. Rear fixing is the reverse of above.

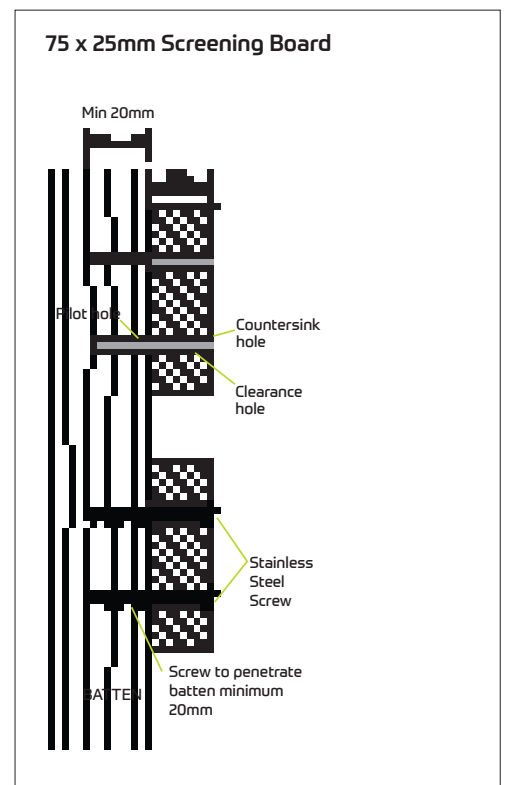
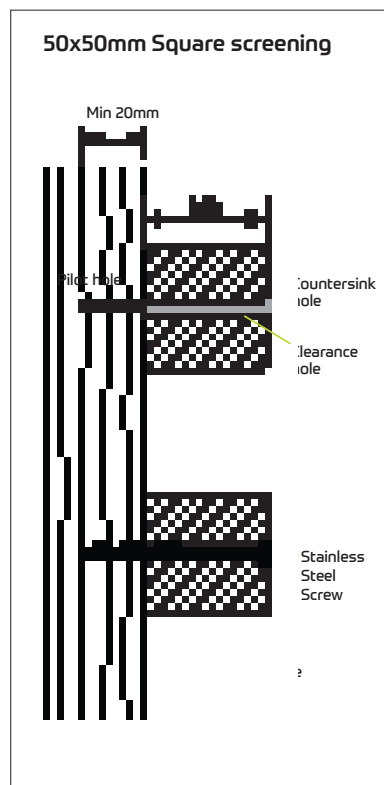

TECHNICAL SPECIFICATIONS	Solid Screening (mm)	Hollow Screening (mm)
Boards / Pack	Various	Various
Number of fasteners per screen width*	1 to 2	1
Maximum Batten centers - Horizontal	600 to 800	600 to 800
Maximum Batten centers - Vertical	600mm to 1.2m	600mm to 1.2m
Maximum Batten to First Fixing Point - Vertical	100 to 200	100 to 200
Minimum clearance from wall (mm)**	5	5
Minimum screening spacing	5	5
Minimum ground clearance	10	10
Minimum clearance at screen end from fixed structure	5	5
Butt gap minimum	4	4

Product can be fixed directly onto a wall with minimal exposure to weathering, using a Sicaflex or other product applied, then screwed to wall.

STORAGE

Storage is simple. Store flat, in a dry area, under cover and out of the sun. Keep your COEN products wrapped in the packaging it arrives onto site. If you need to store your COEN products for a longer than expected period of time, or have a delay in your project, call us at COEN and we'll store your product for you at an agreed price & period of time.



Following our easy-care tips will ensure that your COEN Composite Wood remains the envy of your friends and neighbours for years to come.

NORMAL CARE

COEN composite wood products require periodic cleaning to keep them looking great. For dirt, dust and other residue, simply brush with a soft broom. If necessary, wash the Composite Wood down in the direction of the grain with a garden hose or a pressure washer, no more than 1,500 psi.

PROBLEM	SOLUTION
Dust and Dirt	Wash with hot soapy water and soft scrubbing brush
Mildew	Use a deck washing product or hot soapy water. Never mix any other cleaners with the deck washing product. Cleaning vinegar can be used to kill the mould.
Chalk Stain	Except white, other colours cannot be removed once on the surface, so avoid the use of chalk. Use hot soapy water with a stain-bleaching agent to wipe off.
Ice or snow	Use calcium chloride or rock salt to melt ice or snow and wash with hot soapy water.
Dirty spots or soiling	Apply a detergent with oxalic acid or phosphoric acid to spots and wipe clean after 10-15mins.
Oil	Clean immediately with a household degreasing detergent and hot soapy water.
Berry or wine stain	Scrub and dilute the stains with a mix of bleach and hot soapy water before rinsing with water.
Ink Smudge	An ink smudge is unlikely to be removed. Scrub and dilute the stains with a mix of bleach and hot soapy water before rinsing with water. This may dilute the smudge.

NB: Please note that some cleaners can lighten the colour of your composite wood, so always test any cleaner on a small portion before cleaning the entire surface.

ADDITIONAL TIPS

- Clean wall panelling regularly in order to prevent dust accumulation.
- Remove marks or stains immediately or they may become more difficult to remove after a period of time.
- Never apply harsh solvents such as acetone, gasoline, benzene, carbon tetrachloride or paint thinner.
- Never mix two or more cleaning agents when cleaning your composite wood products.
- Keep the area around your composite wood product clean and well ventilated.
- If you have any further queries, please call us at COEN – 1800 105 031 or email info@coen.com.au