

HABITAT CLADDING

PRODUCT GUIDE
INSTALLATION
TECHNICAL SPECIFICATIONS
CARE & MAINTENANCE

IMPORTANT NOTE – READ ALL SECTIONS BEFORE INSTALLATION

CONTENTS

Important Notes	3 - 4
Wall Cladding Parts and Colours.....	5 - 6
Under Construction	7
Battens Installation	7
Expansion and Contraction Values	8

Wall Cladding-Vertical Installation

-Framing	9 - 12
-Installing the Cladding Board.....	13 - 14
-Installing the last Cladding Board	15- 17
-Final Appearance After Completing the Installation	18

Wall Cladding-Horizontal Installation

-Framing	19 - 20
-Installing the First Board	21 - 22
-Installing the Last Cladding Board	23 - 26
-Final Appearance After Completing the Installation	27

Wall Cladding-Horizontal Installation

Ceiling Installation	28
----------------------------	----

Other

Technical Info and Care Tips	29 - 30
------------------------------------	---------

Note:

Before installing any COEN composite cladding system, consult your local building codes to ensure compliance with specific regulations or restrictions. The diagrams and instructions provided in this guide are for illustrative purposes only and should not be considered a substitute for professional advice. All construction involving COEN products must comply with applicable local zoning and building codes.

Please note: The consumer accepts all risks and liability associated with the installation and use of this product.

Safety Guidelines

As with any construction project, proper safety precautions are essential. COEN recommends the following safety gear when handling, cutting, and installing its products:

- * Gloves
- * Respiratory protection
- * Long sleeves and pants
- * Safety glasses

Use of additional protective equipment may be required depending on the work environment.

Recommended Tools

COEN products can be worked with using standard woodworking tools. For best results, use blades with carbide tips. When fastening, use stainless steel or approved coated deck screws.

Installation Environment

Ensure your installation surface is clean, flat, smooth, and structurally sound. Always verify compliance with local building codes before beginning installation.

If installation is delayed, store COEN products on a flat surface — never on uneven ground.

Planning Your Project

Careful planning will help you achieve the best results.

Since most cladding structures are considered permanent (anchored or attached to a dwelling), permits and inspections are typically required.

To avoid issues:

- * Create a detailed site plan before starting construction
- * Review local building and zoning requirements
- * Factor in layout, drainage, and access

Tip: Before using a pressure washer on your cladding, test it on a scrap piece to ensure it won't damage the product's coating.

Construction Limitations

COEN screening battens must not be used as:

- * Structural columns or support posts
- * Beams or joist stringers
- * Any other primary load-bearing components

All COEN products must be installed on a compliant substructure.

Note: COEN products are not suitable for installation over existing cladding boards.

Heat & Fire Exposure

COEN products may be affected by high surface temperatures from external heat sources, including fire and reflected sunlight. A particular concern is Low-Emissivity (Low-E) glass, commonly used in energy-efficient windows. These windows reflect sunlight, which can cause extreme heat buildup on nearby surfaces.

This excessive heat — beyond typical environmental exposure — may result in:

- * Melting or warping
- * Sagging or discolouration
- * Accelerated weathering
- * Increased expansion and contraction

If you suspect Low-E glass may impact your COEN installation, please contact the glass manufacturer to explore options for reducing or eliminating heat reflection.

Fastening Guidelines

To ensure a secure and clean installation of COEN products:

- * Screws must be driven at a 90-degree angle into the cladding surface.
- * Toe-screwing is not permitted. If a straight angle isn't possible, install an additional joist to support proper screw placement.
- * Each fastener must be on its own joist, and when two board ends meet, they must be supported by a sister batten, ensuring each end is independently supported.

Chalk Lines:

Only use white chalk or guides like string lines or straight boards for marking. Do not use coloured chalk — it can permanently stain COEN surfaces.

Screw Type:

- * Always use stainless steel screws for face-fastening.
- * Composite-specific screws are strongly recommended for the best finish. Check with your local hardware supplier to ensure compatibility.
- * If face-fastening results in bulging or “mushrooming”, gently tap the affected area with a rubber mallet to flatten it and achieve a clean appearance.

Using screws not designed for composite cladding may result in damage. If you're unsure which fasteners to use, consult the product manufacturer for guidance.

Pre-Drilling

When fastening COEN cladding boards, it's recommended to pre-drill holes slightly larger than the screw shank. This allows the material to expand and contract naturally with temperature changes, helping to prevent cracking or deformation.

Refer to the diagram below for visual guidance on proper pre-drilling technique.

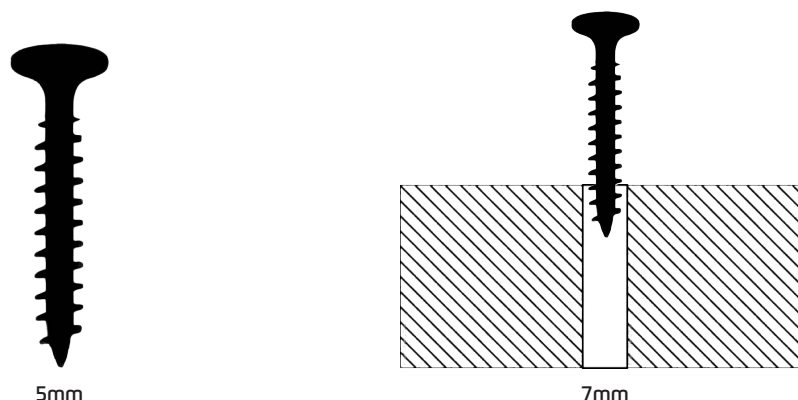

5mm

7mm

CLADDING PARTS

PRODUCT	PURPOSE	IMAGE
SHIPLAP CLADDING	Cladding board, used on walls and ceilings	
CASTELLATED CLADDING	Cladding board, used on walls and ceilings	
CASTELLATED CLADDING STARTER	Starting Trim, used for the installation of the first board	
CASTELLATED CLADDING CORNER	Outside Corner Trim, used on the outside corners	

CLADDING SCREWS*

PURPOSE	TIMBER BATTEN	METAL BATTEN
Used when installing cladding onto battens (Screws not included, sourced/supplied by builder/installer)		

*Note: All screws are based on our recommendation and if the installation requires something different than what is shown, a professional should be consulted before installing. The following installation guide will use the above screw sizes.

CLADDING COLOURS



*Colours are a reference only and may vary to actual product.

Under Construction

We recommend for the under-construction Metal / Aluminium Top Hat Battens or Pre-primed H3 Timber Battens.

Each cladding board needs to be supported by a batten NO MORE than 600 mm on centres.

Extra care is required in order to provide sufficient joisting in and around obstacles such as windows, fascia's, soffits, guttering, ventilation points, etc.

To the right is an example of the layers that would occur in a typical installation, however a licensed professional should always be consulted prior to any installation.

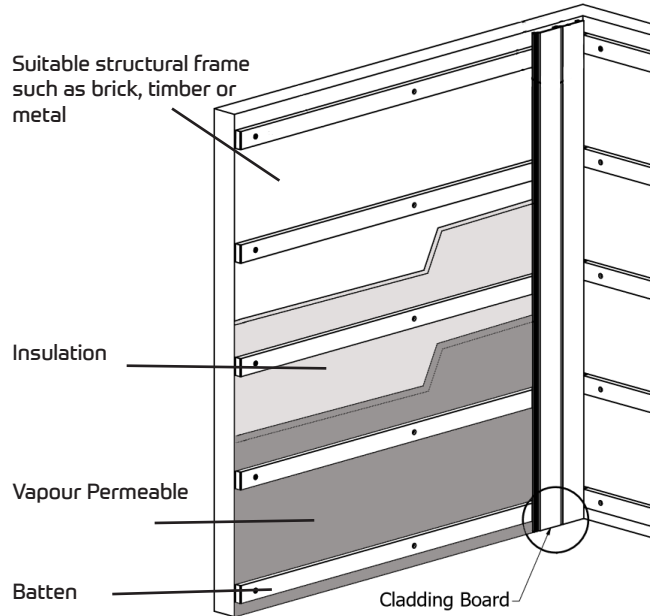

Battens Installation

A building professional should be consulted regarding vapour barriers and insulation for your project. Where a vapour barrier is to be used, it should be a breathable type and must be positioned behind the battens. The batten needs to have a minimum thickness of 25mm.

Battens should be fixed into position at a maximum of 600mm on centres using a suitable A4 Stainless Steel countersunk Wood/Masonry screw. All battens need to be flat and levelled against the wall surface - use shims if necessary.

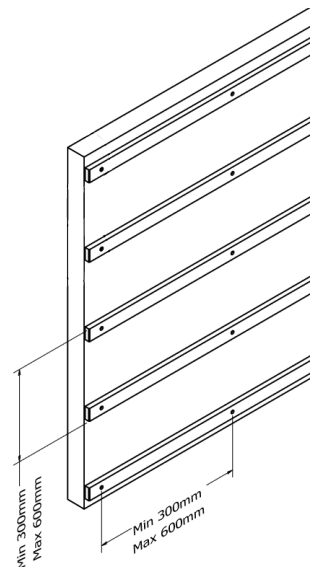
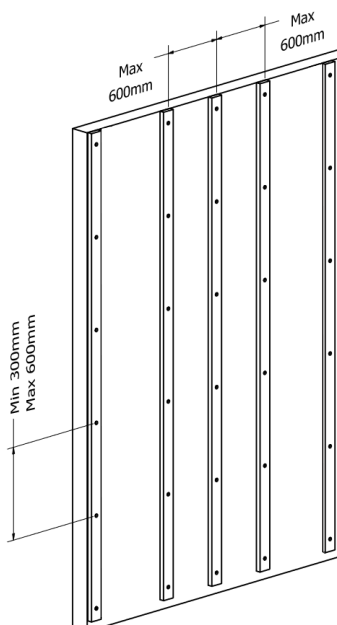

Expansion and Contraction Values

COEN cladding boards will experience expansion and contraction with changes in temperature. Expansion and contraction are most significant where extreme temperature changes occur.

Fastening the cladding boards according to the gapping requirements noted in the following table accommodates for this movement.

		LENGTH IN METERS									
		1	2.44	2.8	3	3.66	3.9	4	4.88	5.4	
INSTALLATION TEMPERATURE IN CELSIUS	10	1.2	3.9	4.5	4.8	5.9	6.2	6.4	7.8	8.6	Gap (mm) To leave Between Boards *
	15	1.4	3.4	3.9	4.2	5.1	5.5	5.6	6.8	7.6	
	20	1.2	2.9	3.4	3.6	4.4	4.7	4.8	5.9	6.5	
	25	1.0	2.4	2.8	3.0	3.7	3.9	4.0	4.9	5.4	
	30	0.8	2.0	2.2	2.4	2.9	3.1	3.2	3.9	4.3	
	35	0.6	1.5	1.7	1.8	2.2	2.3	2.4	2.9	3.2	
	40	0.4	1.0	1.1	1.2	1.5	1.6	1.6	2.0	2.2	
	45	0.2	0.5	0.6	0.6	0.7	0.8	0.8	1.0	1.1	

PLEASE NOTE:

The above shows the overall gap required. If the boards have a gap at each end, then halve the value shown

CALCULATION: Gapping = Coefficient of Linear Expansion (CLE, °C) x Length of the Board (m) x (Max. or Min. Temp. in your region - Installation Temp. °C)

WALL CLADDING VERTICAL INSTALLATION

Installation Procedure

Step 1: Framing

- Measure and Chalk the Battens
- Battens Installation Step 2: Trim Installation

Step 2: Cladding Board Installation

- Installing the First Trim on the starting point
- Installing the First course
- Installing the Second course
- Continuing the remaining installation
- Installing the Last Cladding Board

Step 1 - Framing

The frame needs to be level before installing the cladding boards. Diagram 1 shows the wall replicating different scenarios potentially occurring when installing the cladding boards.

Wall Side A: Cladding between the Outermost Edge and the Inside Corner.

Wall Side B: Cladding between the Outside Corners.

Wall Side C: Cladding between two Outside Corners.

Wall Side D: Cladding between flashings

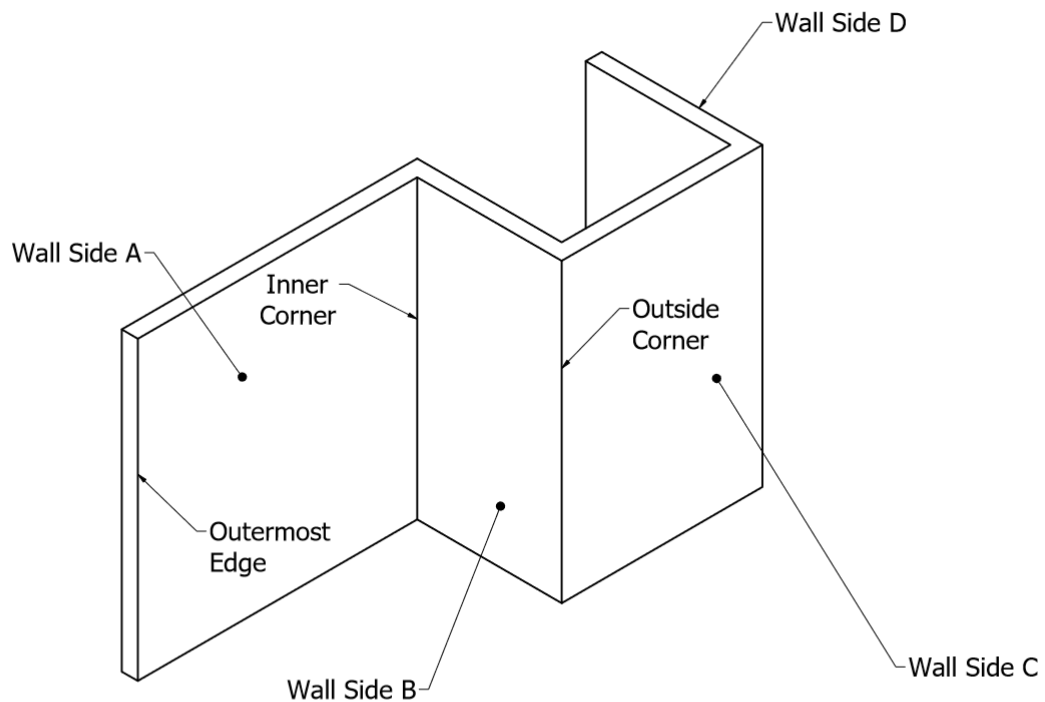

Diagram 1

WALL CLADDING VERTICAL INSTALLATION

Measure and chalk the battens according to the span data specified of this installation guide, as shown in Diagram 2.

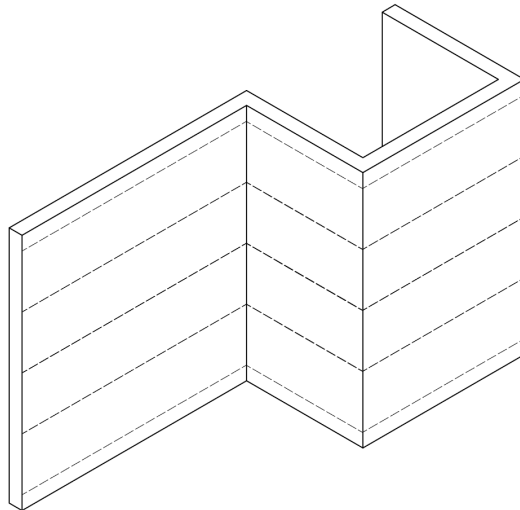

Diagram 2

Please Note:

1. We are using timber battens for this installation. If you are using metal/ aluminium battens, please refer to page 6 of this installation guide for the correct recommended screws.
2. An adequate span between the battens is required to keep the Cladding boards from bending. Please review page 7 of this installation guide to see what span is needed.

Fix the battens onto the wall with screws in the distance at least 300mm and max to 600mm on centre, as shown in Diagram 3.

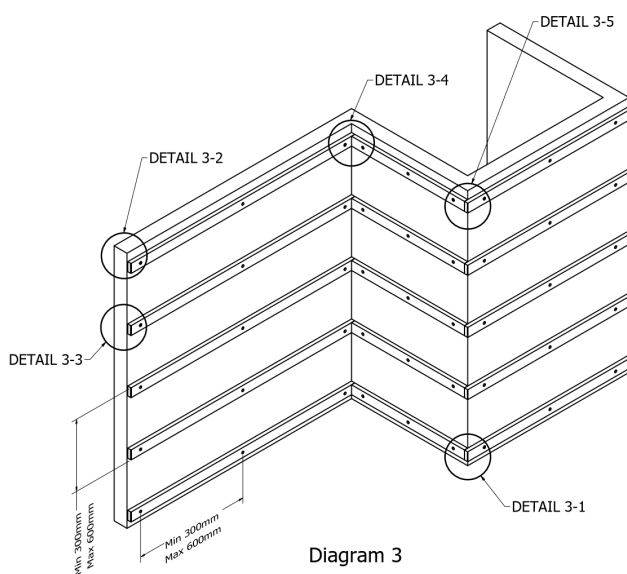
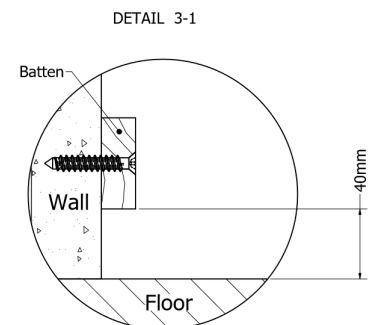

Diagram 3

Please Note:

1. A minimum clearance of 40mm needs to be left between the lowest batten and the floor, as shown in Detail 3-1.



WALL CLADDING VERTICAL INSTALLATION

DETAIL 3-2

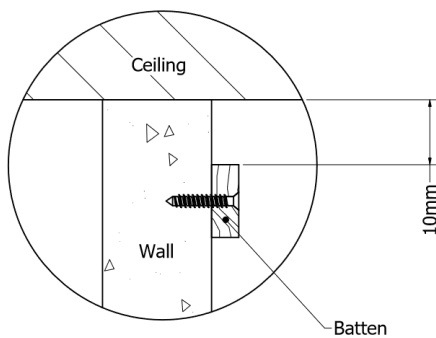

Please Note:

2. A minimum clearance of 10mm needs to be left between the ceiling and the top of the battens, as shown in Detail 3-2.

Please Note:

3. For the Outermost Edge we recommend using aluminium flashing as per Detail 3-3. The Cladding Board and starter clip must be installed prior to the flashing.

4. For the Inside Corner (No trim is needed), please install according to Detail 3-4.

5. For the Outside Corner, we recommend using aluminium flashing this will be installed last - Detail 3-5.

DETAIL 3-3

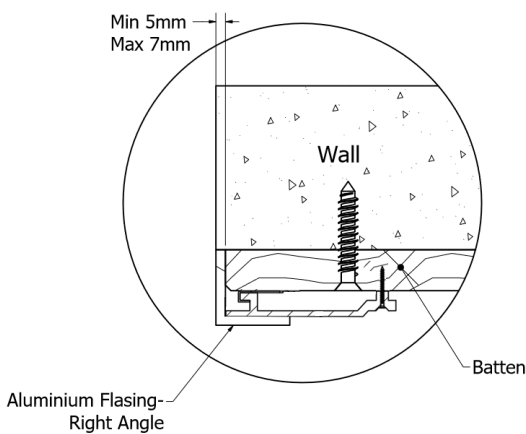

DETAIL 3-4

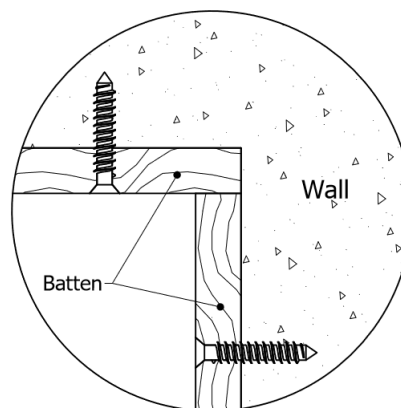

DETAIL 3-5

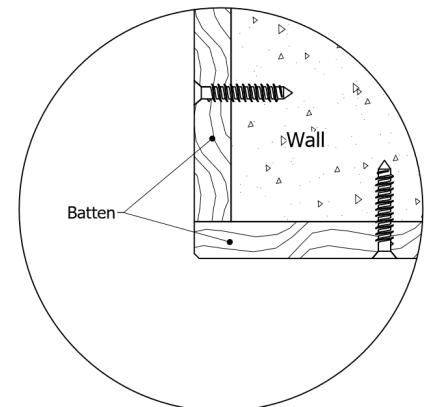

WALL CLADDING VERTICAL INSTALLATION

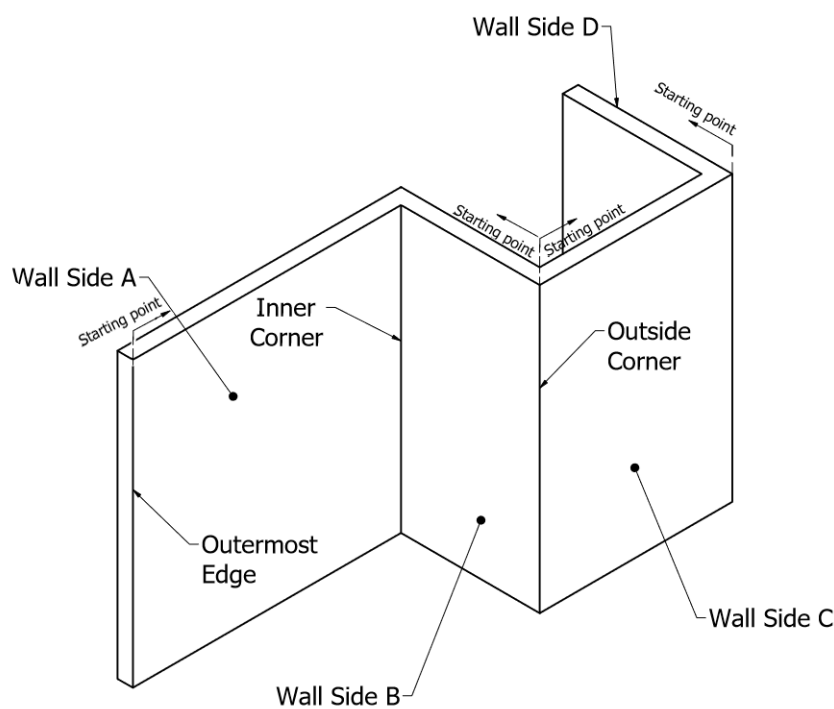

Diagram 4

Please Note:

1. Wall Side A: Cladding between the Outermost Edge. and the Inside Corner Trim.
- Start from the Outermost Edge.
2. Wall Side B: Cladding between the Inside Corner and the Outside Corner.
- Start from the Outside Corner.
3. Wall Side C: Cladding between two Outside Corners,
- Start from one of the Outside Corners.
4. Wall Side D: Cladding between the Outside Corner and the final edge.
- Start from the Outside Corner.

WALL CLADDING VERTICAL INSTALLATION

When starting the installation from the outside corner, fasten the Starter Clip into the batten, insert your Cladding board into it, pre drill with a slight clearance hole into the fixing point of the cladding, then screw the board in. Cladding onto the wall battens with screws, then cover with aluminium flashing* as shown in Diagram 5 and Detail 5-1.

Please Note:

Since the composite wood must allow for expansion and contraction due to temperature change, the board must have a clearance hole when installed to allow the board to move freely.

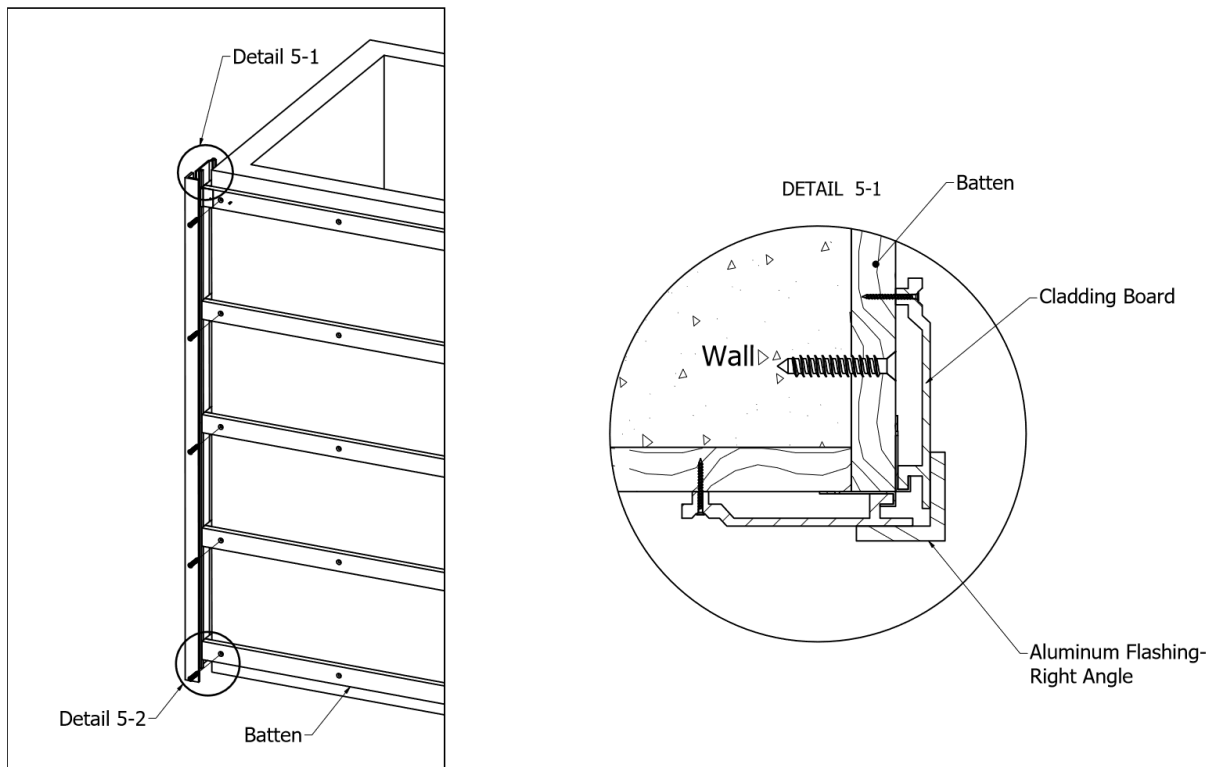

Diagram 5

Please Note:

* Aluminium flashing can be installed once all of the cladding as been finished.

WALL CLADDING VERTICAL INSTALLATION

To continue the run of the wall insert your next Cladding board into the first, pre drill with a slight clearance hole into the fixing point of the cladding, then screw the board in. Simply repeat this process. As shown in Detail 6-1.

Please Note:

Since the composite wood must allow for expansion and contraction due to temperature change, the board must have a clearance hole when installed to allow the board to move freely.

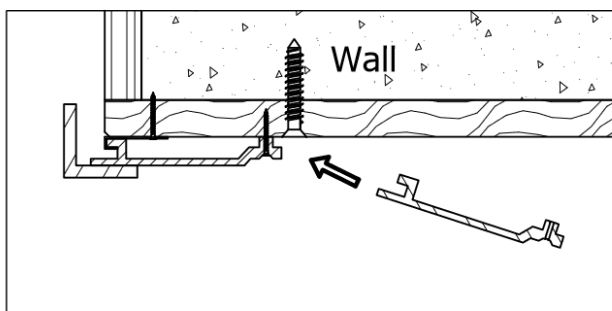
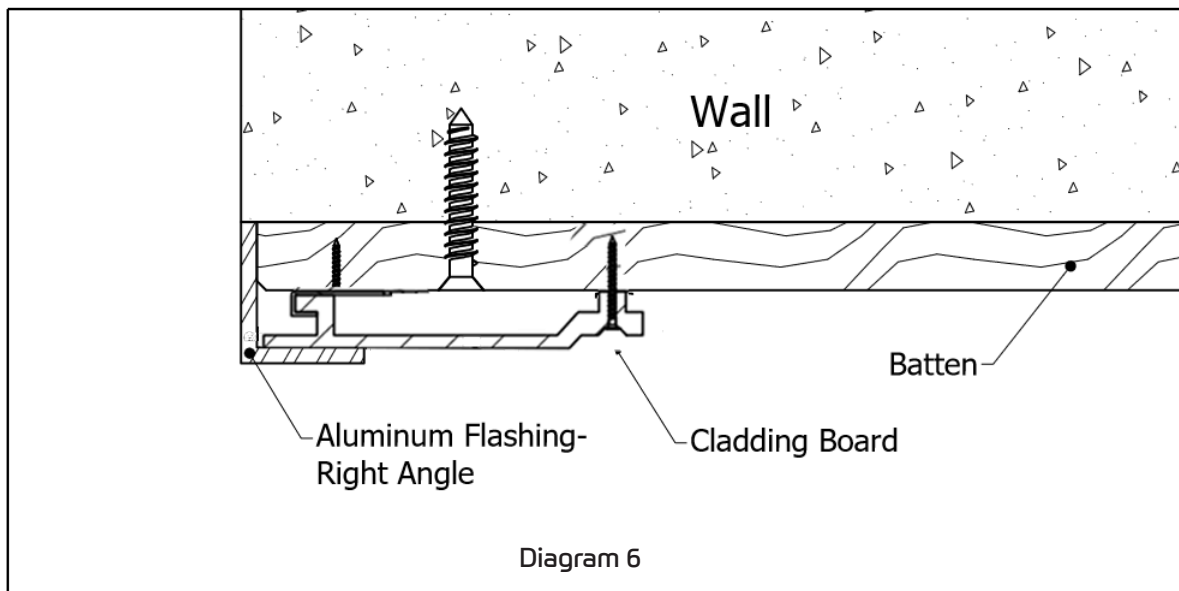

Detail 6-1

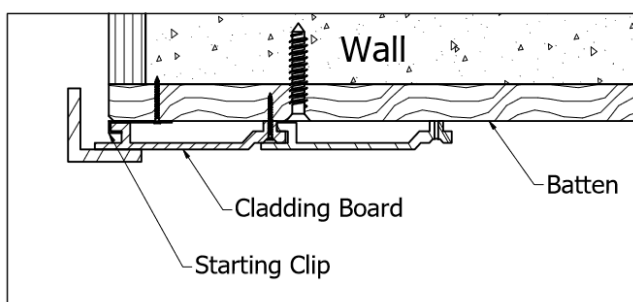

Please Note:

The gap between the cladding board and the floor should be at least 20mm, as shown in Diagram 7.

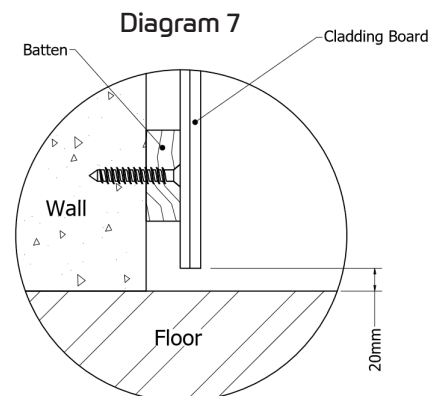

WALL CLADDING VERTICAL INSTALLATION

When you are at the last board, please measure the distance to obtain the appropriate board's ripping dimension

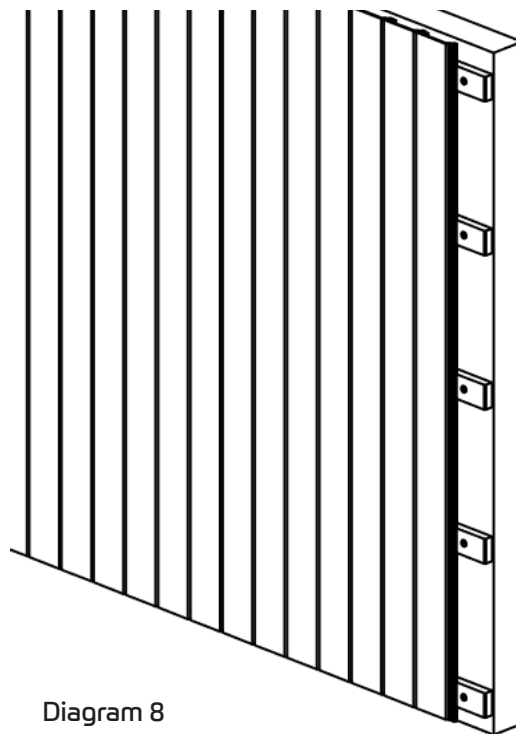

Diagram 8

Rip the board according to the measured dimension as shown in Diagram 9 and Detail 9-1.

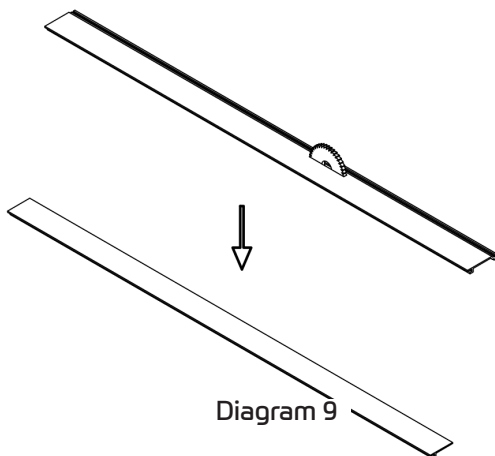
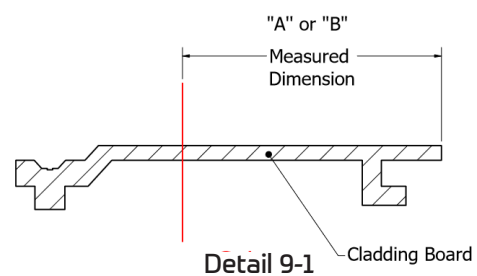

Diagram 9

Diagram 10



DETAIL 10-1

WALL CLADDING VERTICAL INSTALLATION

Next Install the Rubber Stopper onto each batten with screws. As seen in Diagram 10 This can also be achieved with another batten, or alternate packing material, ensuring that it is 14mm..

Slide the last cladding board into place, ensuring the product is level and square as shown in Diagram 11

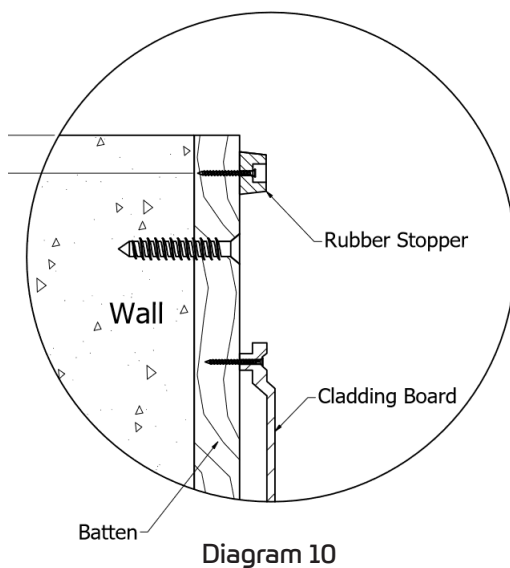

Please Note:

The gap between the cladding board and the floor should be at least 20mm, as shown in Detail 7-4.

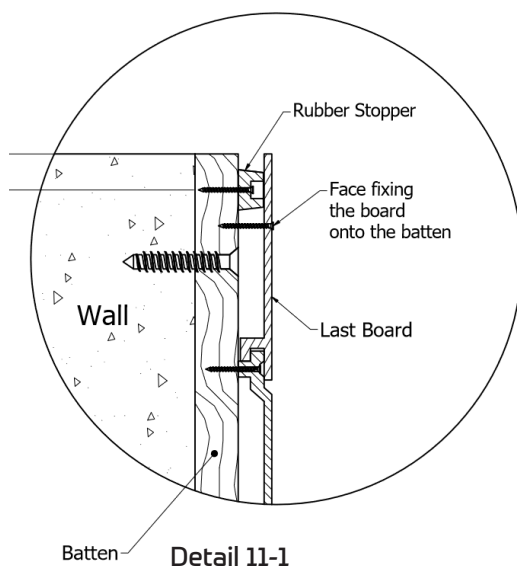
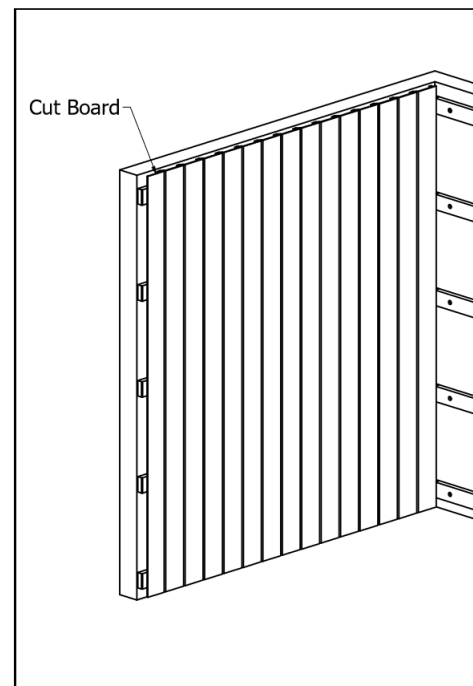

Pre drilling with a clearance hole, screw the cladding board into place. As seen in Detail 11-1

Please Note:

Since the composite wood must allow for expansion and contraction due to temperature change, the board must have a clearance hole when installed to allow the board to move freely.

WALL CLADDING VERTICAL INSTALLATION

Next Install the Aluminium flashing to conceal the ripped down edge. Diagrams 12 and 13 show the installation onto the outermost edge and external corner.

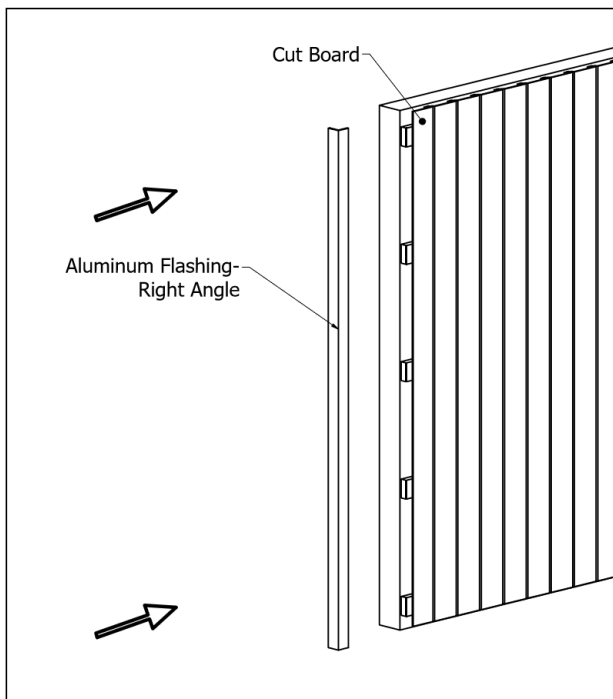

Diagram 12

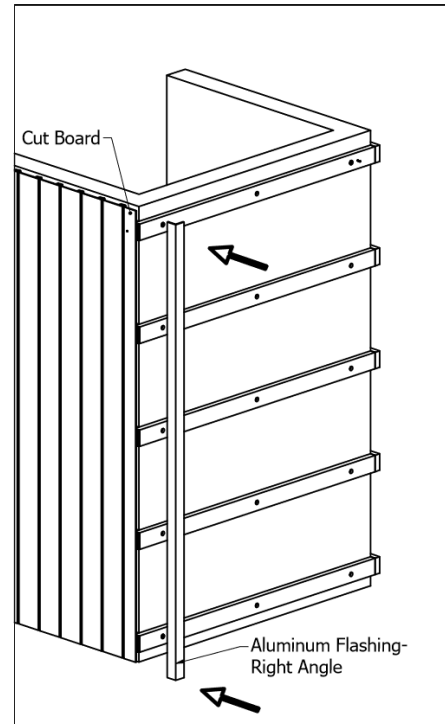
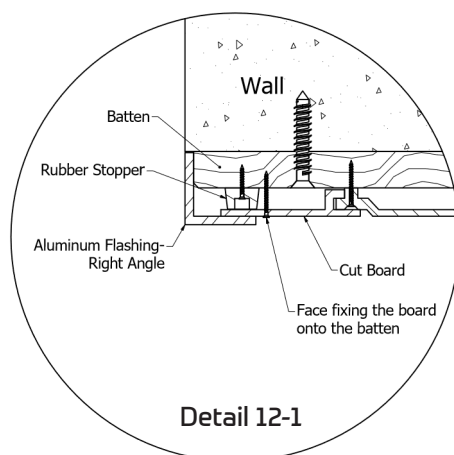
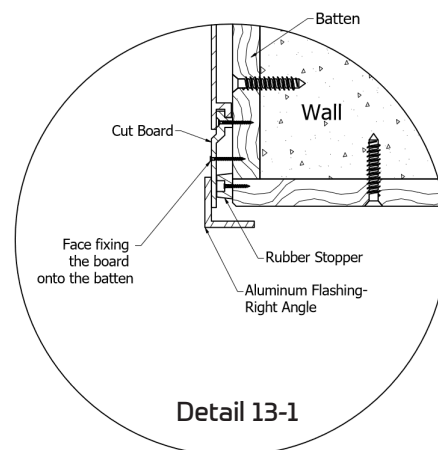

Diagram 13



Detail 12-1



Detail 13-1

Please Note:

COEN does not supply the aluminium flashing, however we can provide colour codes to match the product colour.

Ask your builder or local aluminium supplier for best installation methods.

WALL CLADDING VERTICAL INSTALLATION

Diagram 14 showcases the finished vertical cladding. The aluminium flashing can be seen in grey. The flashing can also be added to the top and bottom of the cladding.

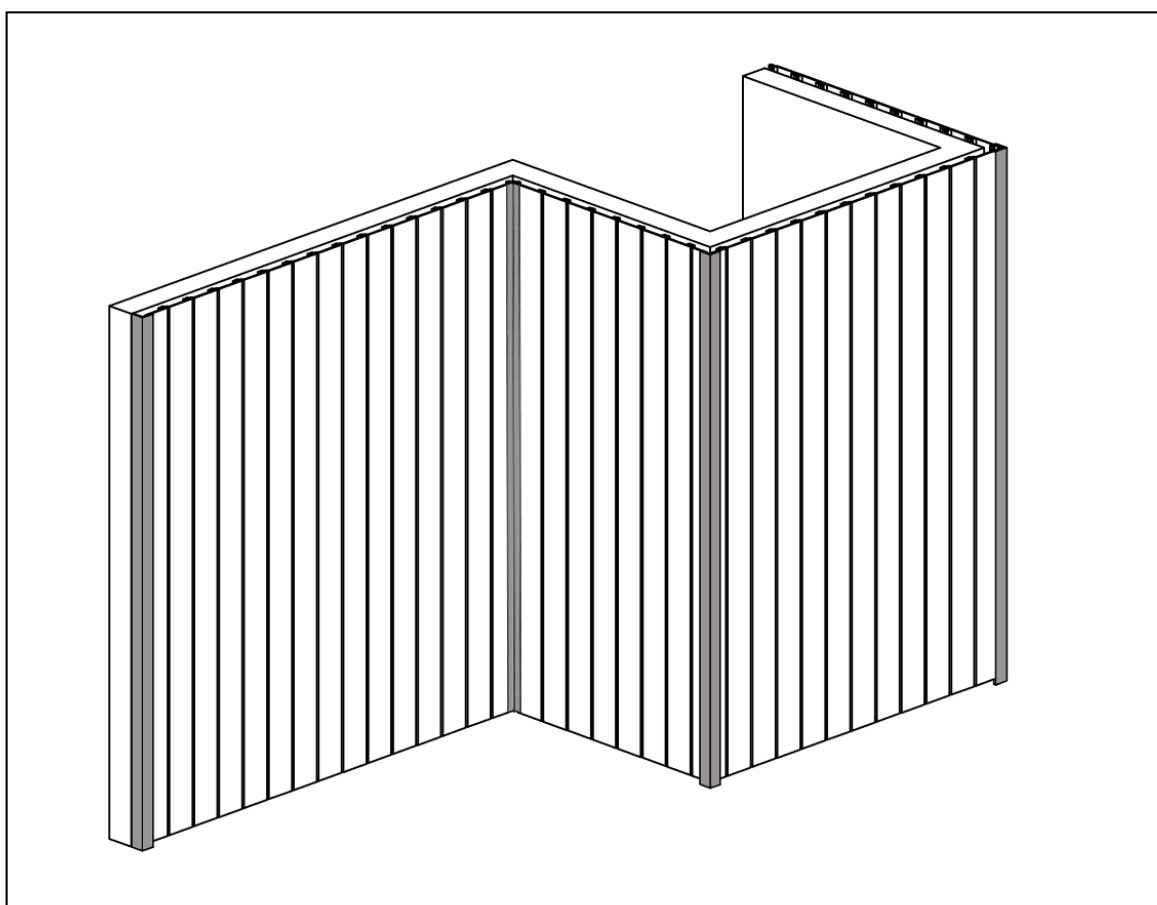

Diagram 14

Please Note:

COEN does not supply the aluminium flashing, however we can provide colour codes to match the product colour.

Ask your builder or local aluminium supplier for best installation methods.

WALL CLADDING HORIZONTAL INSTALLATION

Installation Procedure

Step 1: Framing

- Measure and Chalk the Battens
- Battens Installation

Step 2: Cladding Board Installation

- Installing the First course
- Installing the Second course
- Continuing the remaining installation
- Installing the Last Cladding Board

Step 1 - Framing

The frame needs to be level before installing the cladding boards. Diagram 1 shows the wall replicating different scenarios potentially occurring when installing the cladding boards.

Wall Side A: Cladding between the Outermost Edge and the Inside Corner.

Wall Side B: Cladding between the Outside Corners.

Wall Side C: Cladding between two Outside Corners.

Wall Side D: Cladding between flashings

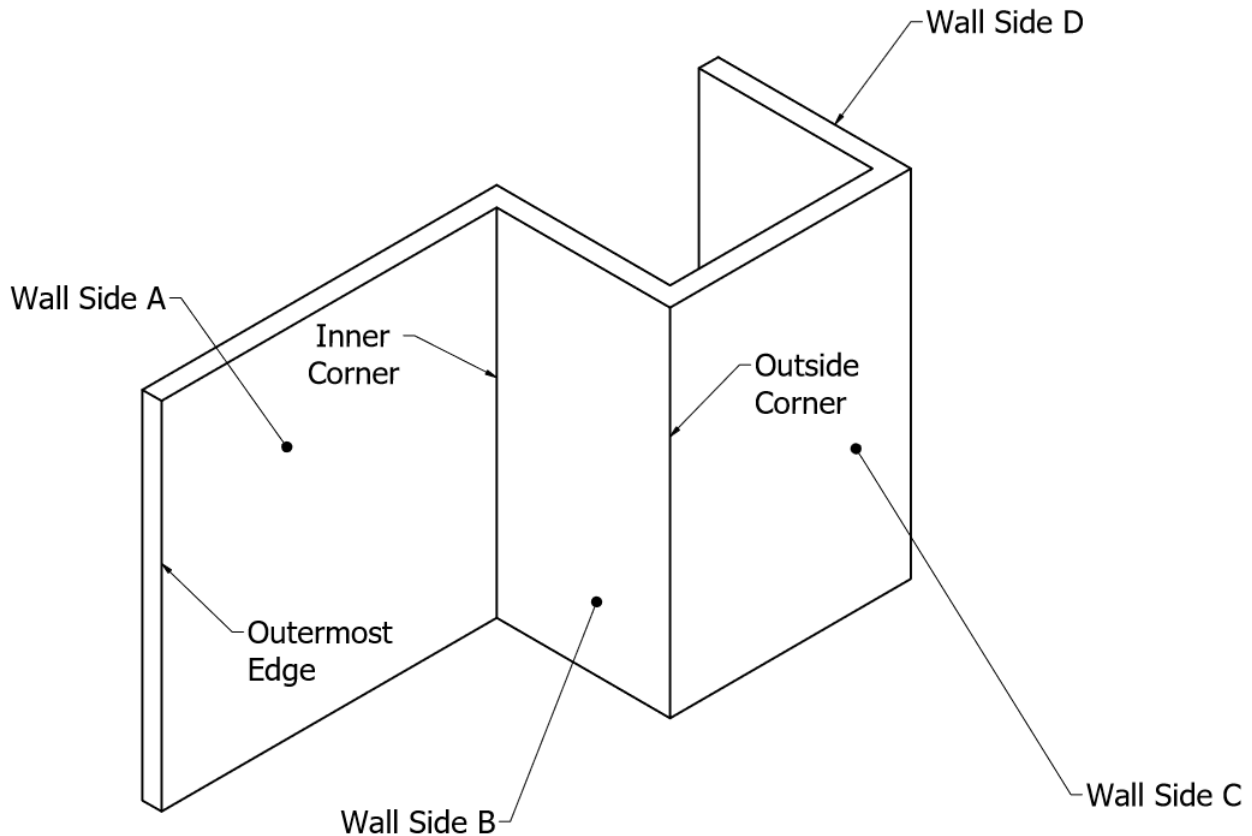

Diagram 15

WALL CLADDING HORIZONTAL INSTALLATION

Measure and chalk the battens according to the span data specified on page 10 of this installation guide. Fix the battens onto the wall with screws in the distance at least 300mm and max to 600mm as shown in Diagram 16.

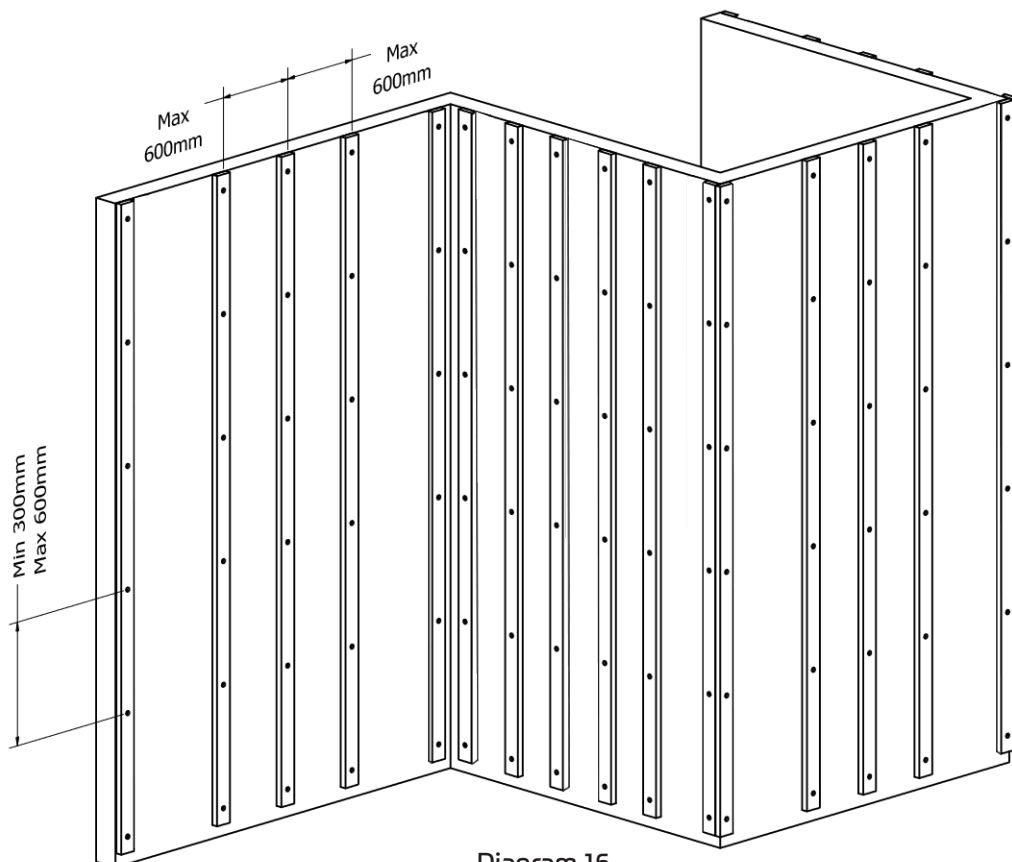
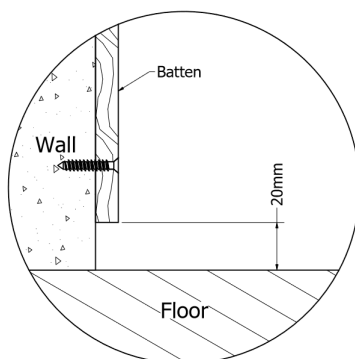

Diagram 16

Detail 16-1



Please Note:

An adequate span between the battens is required to keep the Cladding boards from bending. Please review page 7 of this installation guide to see what span is needed.

A min gap of 20 mm needs to be left at the bottom of each batten against the floor, as shown in Detail 16-1.

WALL CLADDING HORIZONTAL INSTALLATION

Measure and screw in your starter clips at the bottom of the battens. Place your Cladding board into the starter clips, then predrill a slight clearance hole and screw the Cladding to the batten. As seen in Detail 17.1.

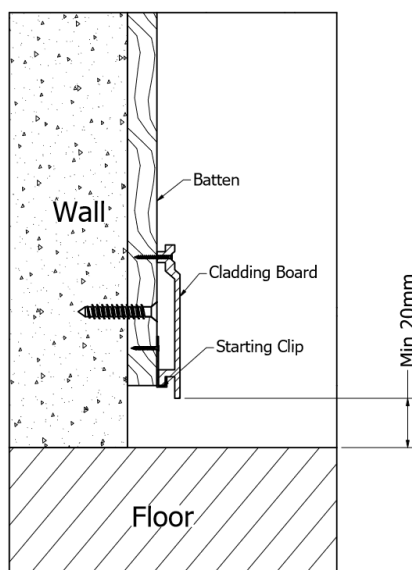
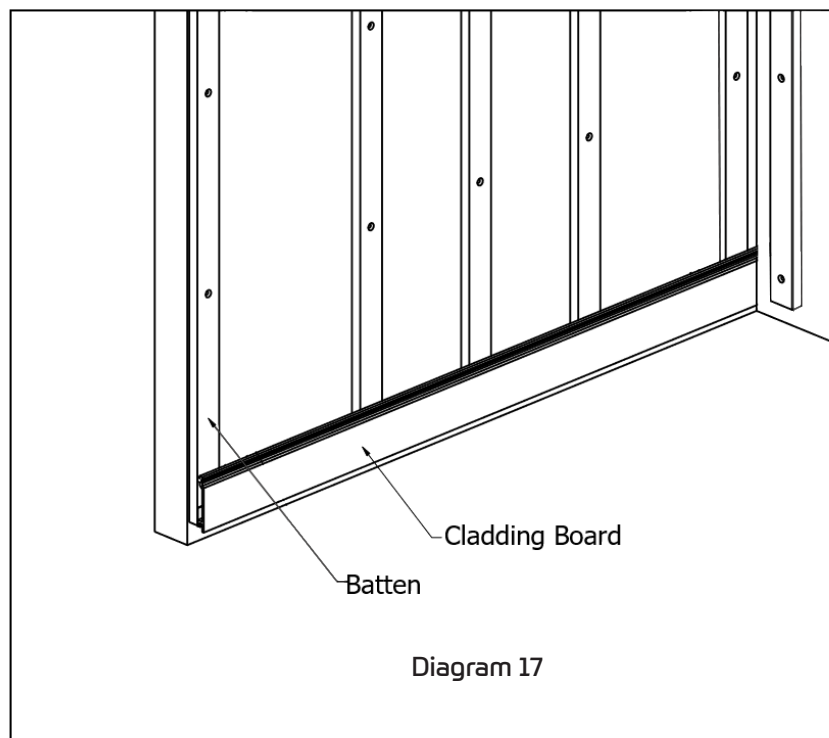

Please Note:

Since the composite wood must allow for expansion and contraction due to temperature change, the board must have a clearance hole when installed to allow the board to move freely.

A min gap of 20 mm needs to be left at the bottom of each batten against the floor, as shown in Detail 17-1.

WALL CLADDING HORIZONTAL INSTALLATION

Place your Cladding board into the first board, ensure it is level, then predrill a slight clearance hole and screw the Cladding to the batten as seen in Detail 18.1.

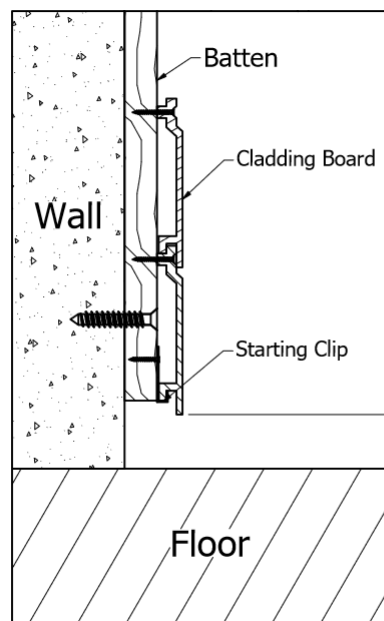
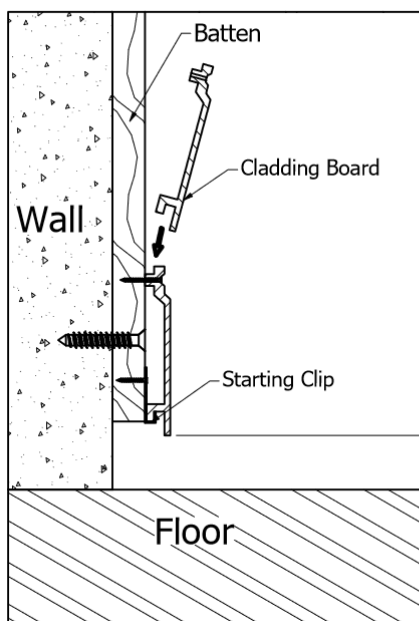
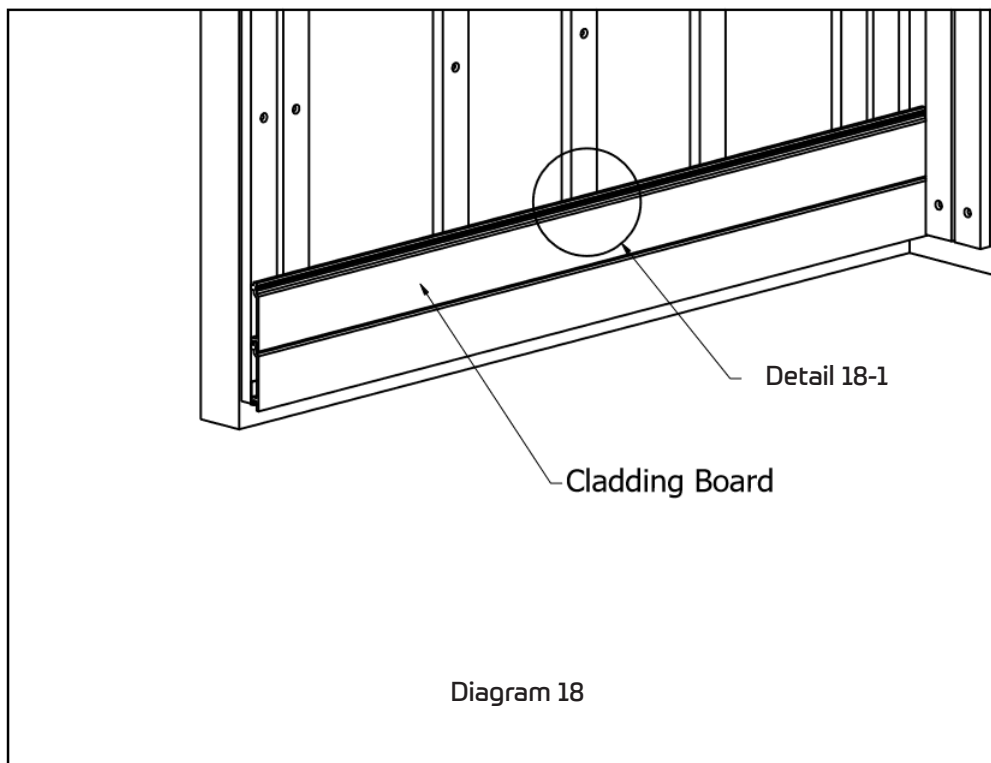

Detail 18-1

Please Note:

Since the composite wood must allow for expansion and contraction due to temperature change, the board must have a clearance hole when installed to allow the board to move freely.

Min 20mm

WALL CLADDING HORIZONTAL INSTALLATION

When you are at the last board, please measure the distance to obtain the appropriate board's ripping dimension. As shown in Diagram 19 and Detail 19-1.

Rip the board according to the measured dimension as shown in Diagram 20 and Detail 20-1.

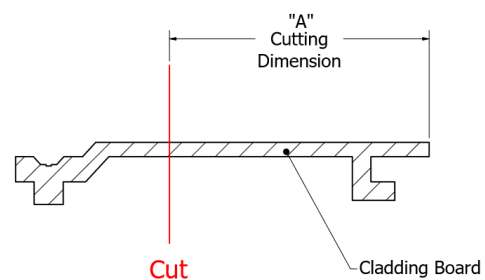
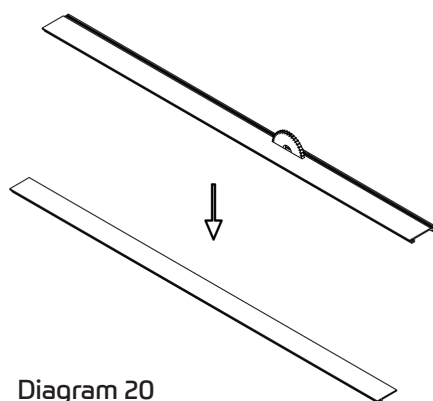
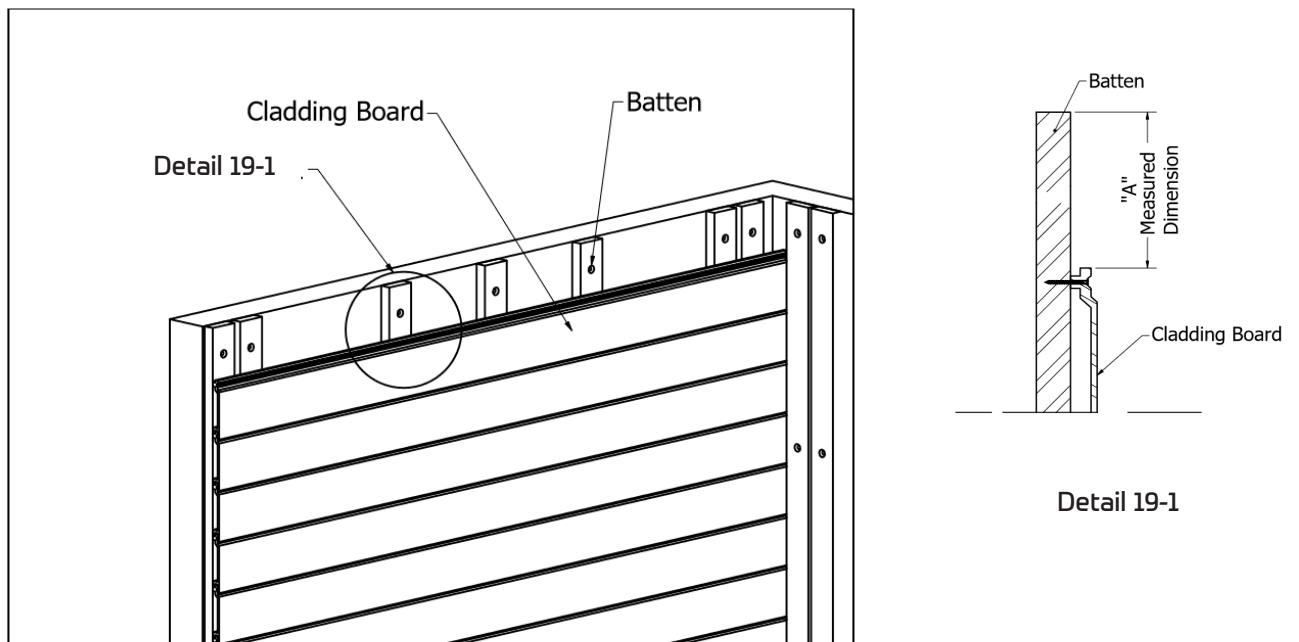

Please Note:

Since the composite wood must allow for expansion and contraction due to temperature change, the board must have a clearance hole when installed to allow the board to move freely.

WALL CLADDING HORIZONTAL INSTALLATION

Next Install the Rubber Stopper onto each batten with screws. As seen in Diagram 21. This can also be achieved with another batten, or alternate packing material, ensuring that it is 14mm.

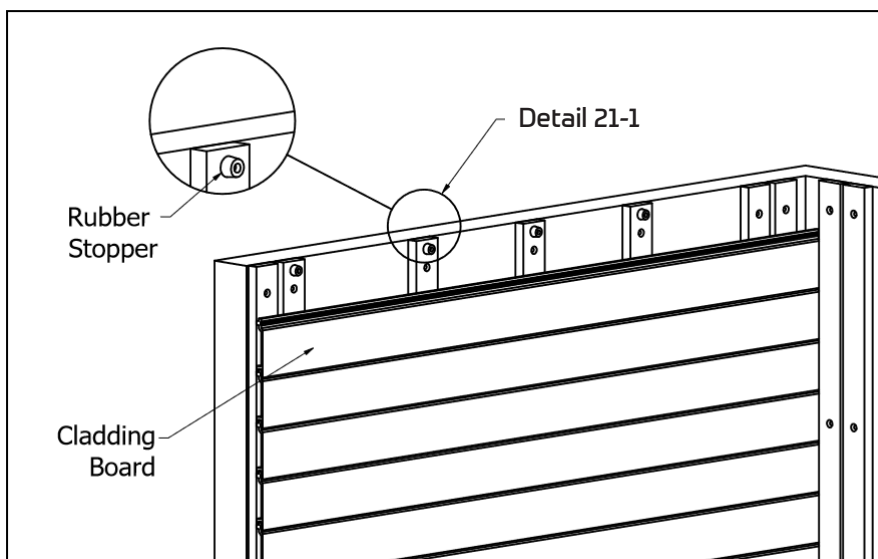
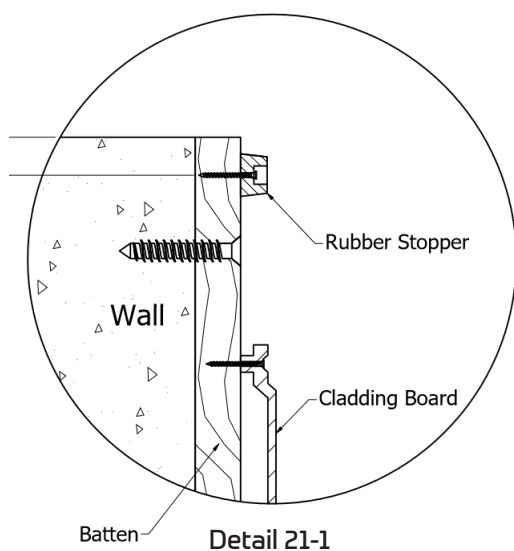

Diagram 21



WALL CLADDING HORIZONTAL INSTALLATION

Slide the last cladding board into place, ensuring the product is level and square as shown in Diagram 11

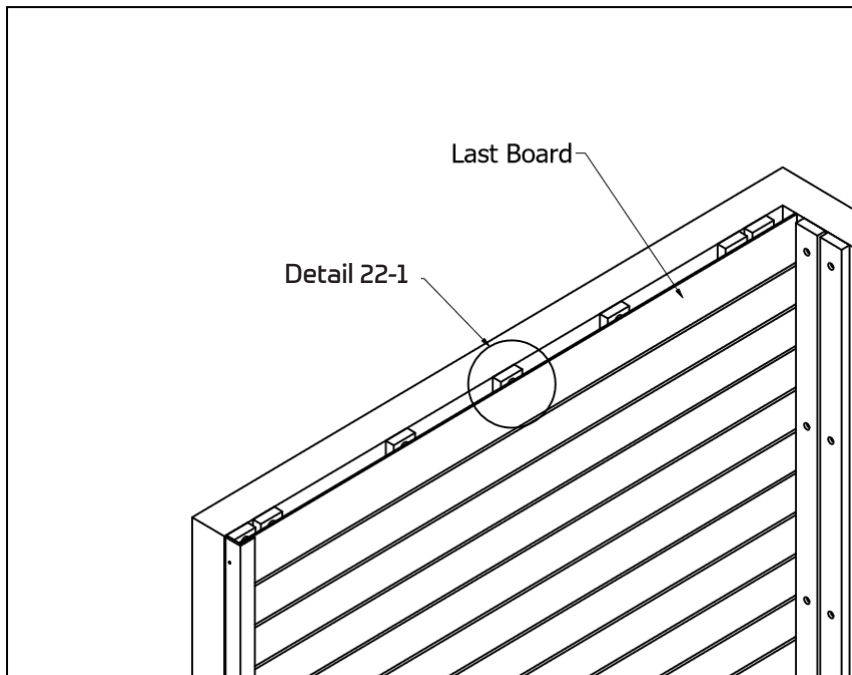
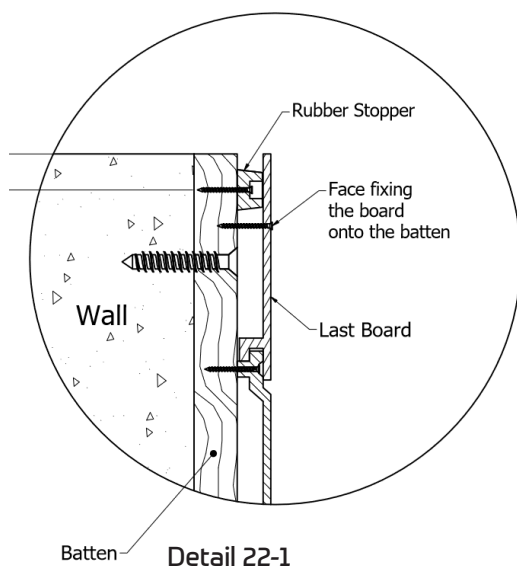

Diagram 22



Pre drilling with a clearance hole, screw the cladding board into place. As seen in Detail 22-1

Please Note:

Since the composite wood must allow for expansion and contraction due to temperature change, the board must have a clearance hole when installed to allow the board to move freely.

WALL CLADDING HORIZONTAL INSTALLATION

Next Install the Aluminium flashing to conceal the ripped down edge. Diagram 23 and Detail 23-1 show the installation onto the outermost edge.

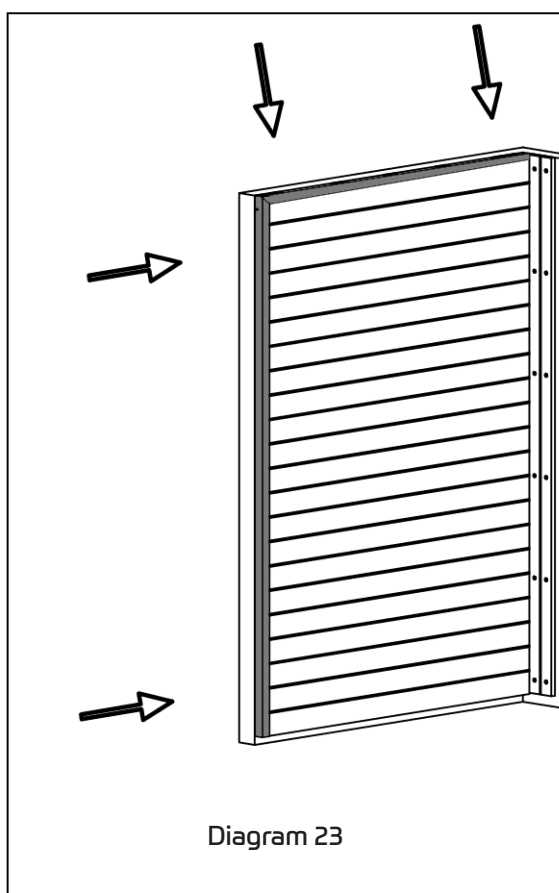
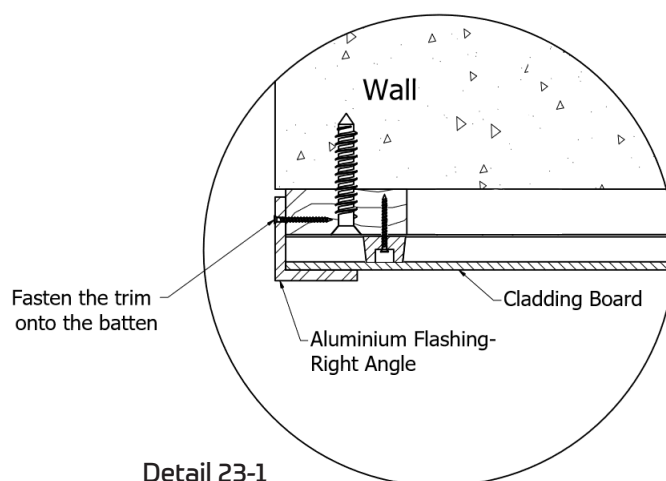

Diagram 23



Detail 23-1

Please Note:

COEN does not supply the aluminium flashing, however we can provide colour codes to match the product colour.

Ask your builder or local aluminium supplier for best installation methods.

WALL CLADDING HORIZONTAL INSTALLATION

Diagram 24 showcases the finished horizontal cladding. The aluminium flashing can be seen in grey. The flashing can also be added to the top and bottom of the cladding.

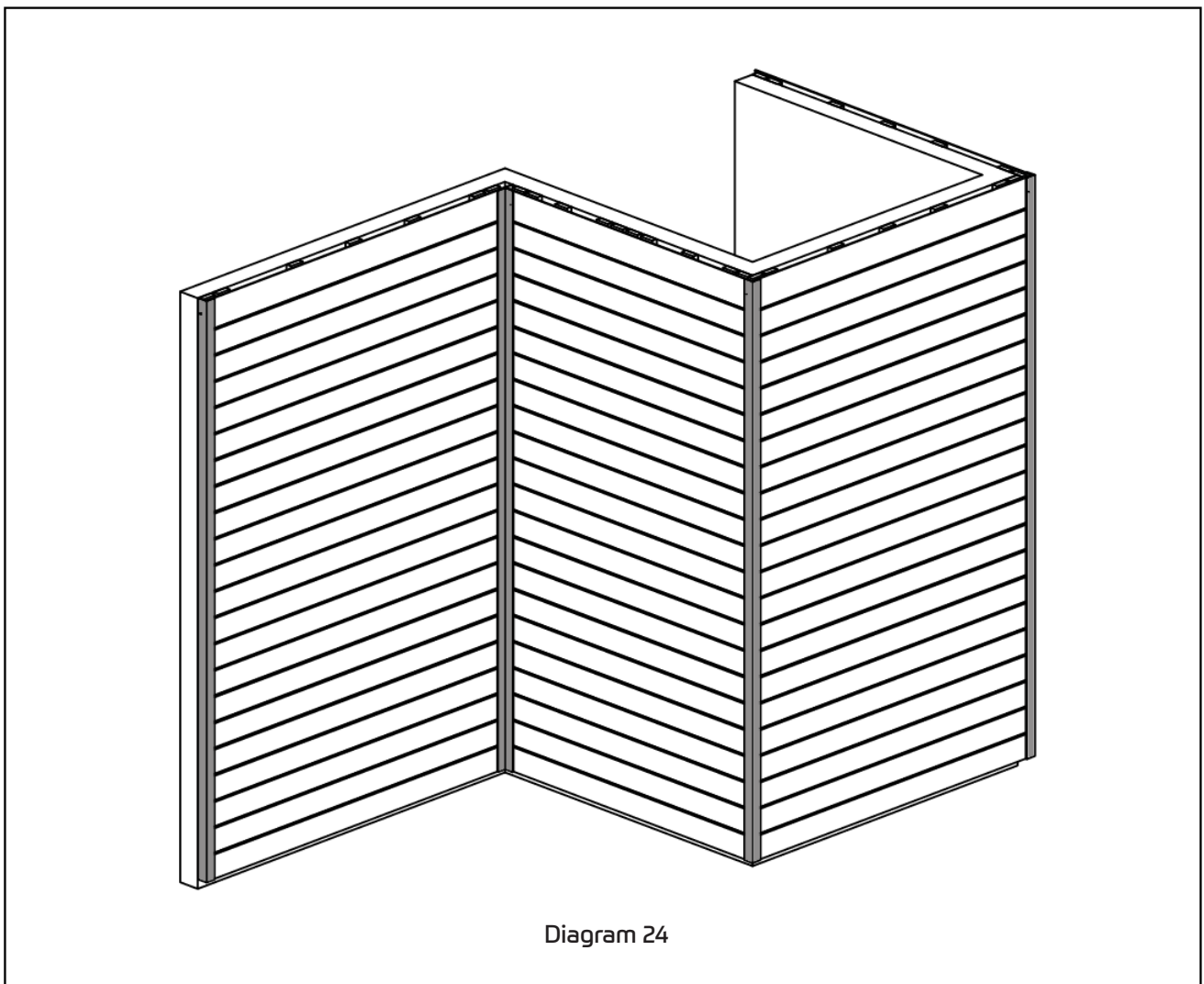

Please Note:

COEN does not supply the aluminium flashing, however we can provide colour codes to match the product colour.

Ask your builder or local aluminium supplier for best installation methods.

WALL CLADDING CEILING INSTALLATION

The installation process follows the same principals as the above Horizontal and Vertical installations.

The only change is to ensure that your battens are spaced no more than 300mm, as shown in Diagram 25.

All other information is required to be followed, since the composite wood must allow for expansion and contraction due to temperature change, the board must have a clearance hole when installed to allow the board to move freely.

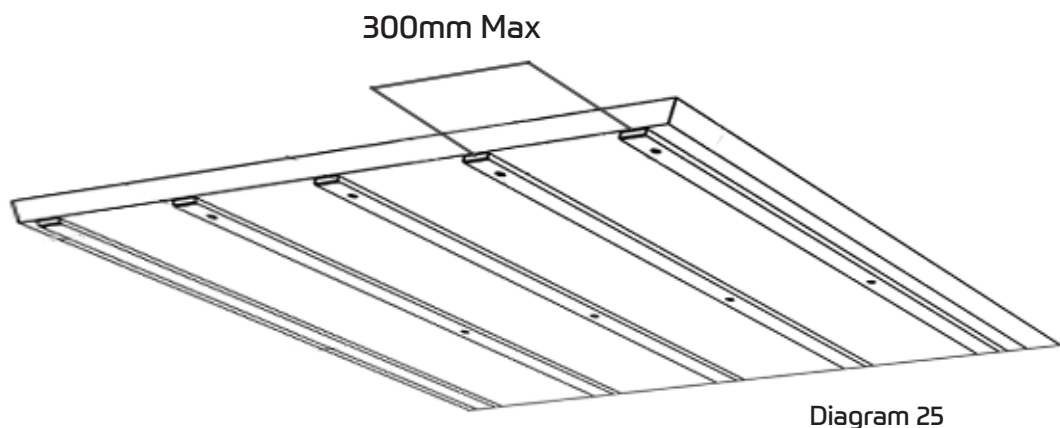

If you have any questions during the installation process, feel free to reach out to the COEN team for support.

Contact us on 1800 105 031 or email us at info@coen.com.au

We look forward to seeing your finished project!

TECHNICAL SPECIFICATIONS	SHIPLAP	CASTELLATED	Comments
Dimensions and Weight	156 x 21mm x 5.4m 9.2KG	220 x 28mm x 2.9m 8.9KG	Brushed Finish
Boards / Pack	200	85	
Minimum ground clearance	100	100	
Minimum clearance over concrete	20	20	
Batten centers (min & max distance) – Domestic	300 to 600	300 to 600	In high wind areas, batten spacing should be 300mm
Batten size min	40 X 25	40 X 25	
Batten with but joining min	100 X 30	100 X 30	
Minimum end-gap (butt join)	4mm	4mm	
Maximum overhang from last batten	50	50	
Screw distance from cladding board edges	Min 15, max 25	Min 15, max 25	
Fastening screws			Screws must comply with AS 3566 Self Drilling Screws for the Building and Construction Industries.

STORAGE

Storage is simple. Store flat, in a dry area, under cover and out of the sun. Keep your COEN products wrapped in the packaging it arrives onto site. If you need to store your COEN products for a longer than expected period of time, or have a delay in your project, call us at COEN and we'll store your product for you at an agreed price & period of time.

Following our easy-care tips will ensure that your Cladding remains the envy of your friends and neighbours for years to come.

NORMAL CARE

COEN composite wood products require periodic cleaning to keep them looking great. For dirt, dust and other residue, simply brush with a soft broom. If necessary, wash the Composite Wood down in the direction of the grain with a garden hose or a pressure washer, no more than 1,500 psi.

PROBLEM	SOLUTION
Dust and Dirt	Wash with hot soapy water and soft scrubbing brush
Mildew	Use a deck washing product or hot soapy water. Never mix any other cleaners with the deck washing product. Vinegar can be used to kill the mould.
Chalk Stain	Except white, other colours cannot be removed once on the surface, so avoid the use of chalk. Use hot soapy water with a stain-bleaching agent to wipe off.
Ice or snow	Use calcium chloride or rock salt to melt ice or snow and wash with hot soapy water.
Dirty spots or soiling	Apply a detergent with oxalic acid or phosphoric acid to spots and wipe clean after 10-15mins.
Oil	Clean immediately with a household degreasing detergent and hot soapy water.
Berry or wine stain	Scrub and dilute the stains with a mix of bleach and hot soapy water before rinsing with water.
Ink Smudge	An ink smudge is unlikely to be removed. Scrub and dilute the stains with a mix of bleach and hot soapy water before rinsing with water. This may dilute the smudge.

Note: Please note that some cleaners can lighten the colour of your composite wood, so always test any cleaner on a small portion before cleaning the entire surface.

ADDITIONAL TIPS

- Clean wall paneling regularly in order to prevent dust accumulation.
- Remove marks or stains immediately or they may become more difficult to remove after a period of time.
- Never apply harsh solvents such as acetone, gasoline, benzene, carbon tetrachloride or paint thinner.
- Never mix two or more cleaning agents when cleaning your composite wood products.
- Keep the area around your composite wood product clean and well ventilated.
- If you have any further queries, please call us at COEN – 1800 105 031 or email info@coen.com.au